



BX 19 GTI

"L3.1 JETRONIC"

SUMMARY

	Pages
Operating principle	2
Electrical circuit diagrammes	3,4
Checking the electrical supplies :	
• battery (+ direct)	5
• + after ignition switch	5
• + after starter motor switch	6
Checking the throttle spindle switch "192"	6
Adjusting the throttle butterflies initial position	7
Adjusting the throttle spindle switch "192"	8
Checking the flowmeter "302"	9
Checking the supplementary air control "280"	10
Checking the injectors "576"	10
Checking the coolant temperature sensor "841"	11
Mixture checking and setting at idle	12



ELECTRICAL SYSTEM COMPONENTS

Number	Description	Made by	Reference	RP No.
45	Battery			
50	Ignition coil			
142	Fuel injection control unit	BOSCH	0 280 000 601	91 535 086
168	Battery connector			
192	Throttle spindle switch	BOSCH	0 280 120 310	91 519 925
229	Antitheft / ignition switch			
280	Supplementary air control	BOSCH	0 280 120 311	91 536 077
302	Flowmeter	BOSCH	0 280 202 602	91 536 076
576	Injectors	BOSCH	0 280 150 725	91 538 369
683	Fuel pump	BOSCH	0 580 464 008	5 471 660
731	Injection relay			91 000 409
734	Injector relays			91 000 409
841	Coolant temperature sensor (for injection)	BOSCH	0 280 130 026	91 514 549

Page 3 : location of the components in the vehicle

Page 4 : injection electrical circuit diagram

PRINCIPLE OF OPERATION

The fuel is sprayed under a low pressure (2.5 bars approx.) upstream of the inlet valve by electronically controlled injectors. The excitation time for the injectors is very short (between 2 and 10 milli-seconds). The amount of fuel injected depends from the various informations the E.C.U receives.

1) *Main parameters :*

- Quantity of air drawn into the cylinders : flowmeter "302"
- Engine rotational speed : ignition coil "50"

2) *Secondary information :*

- Engine temperature : water temperature sensor "841"
- Temperature of the air entering the cylinders : air temperature sensor (in the flowmeter)
- Slow running, partial load, full engine load and deceleration : switch fitted on the throttle butterfly spindle (192) extremity

3) *Special secondary information :*

- Enrichment during rapid acceleration : flowmeter (rapid movement of the flap)
- Enrichment after operation of the starter motor (independent of the engine temperature)
- Correction depending on the battery voltage.

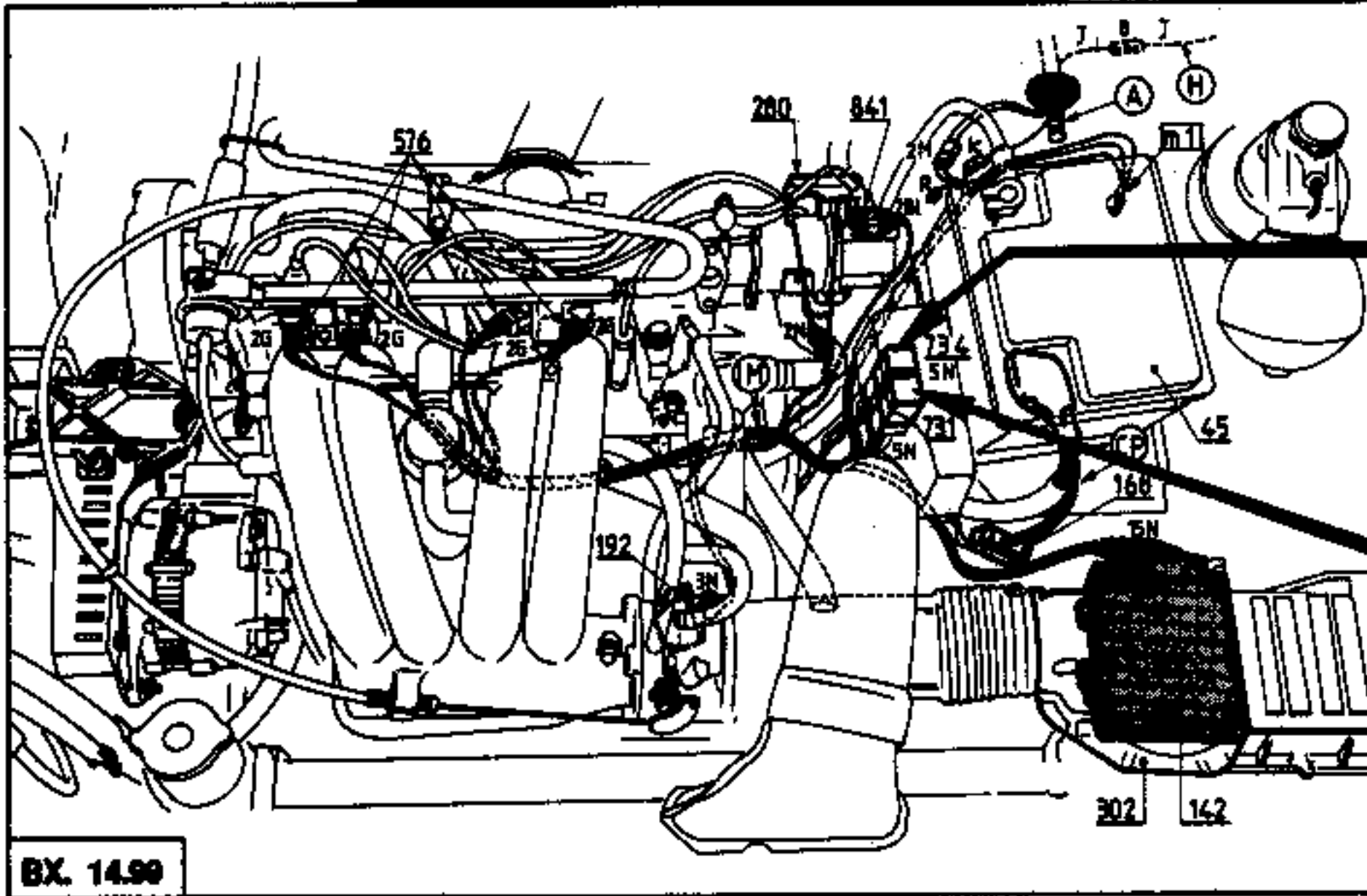

BX. 14.90

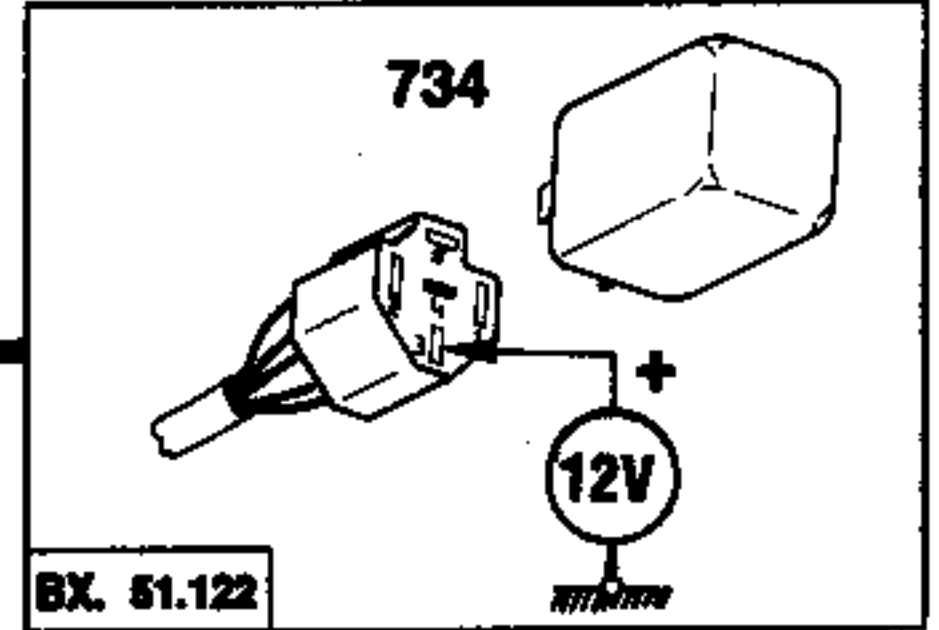

BX. 51.122

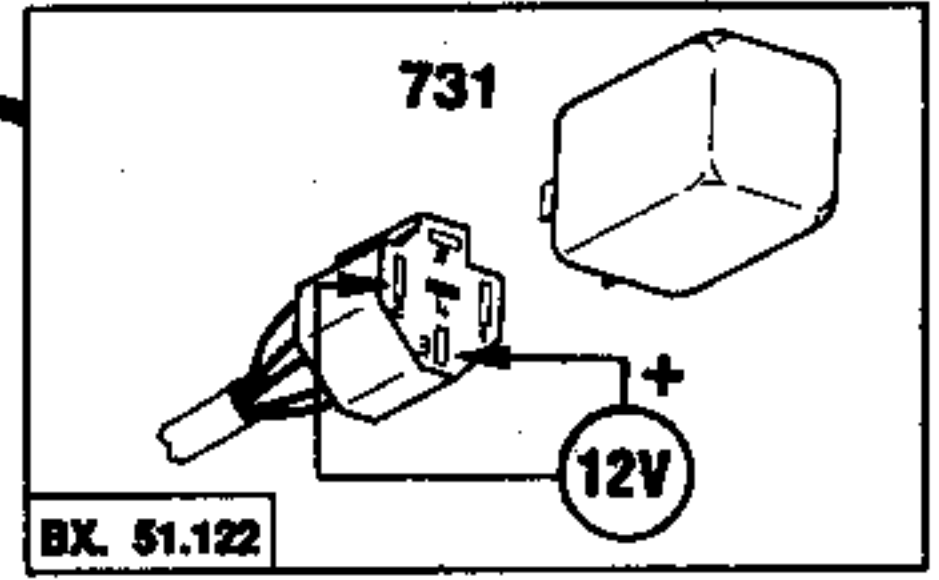

BX. 51.122

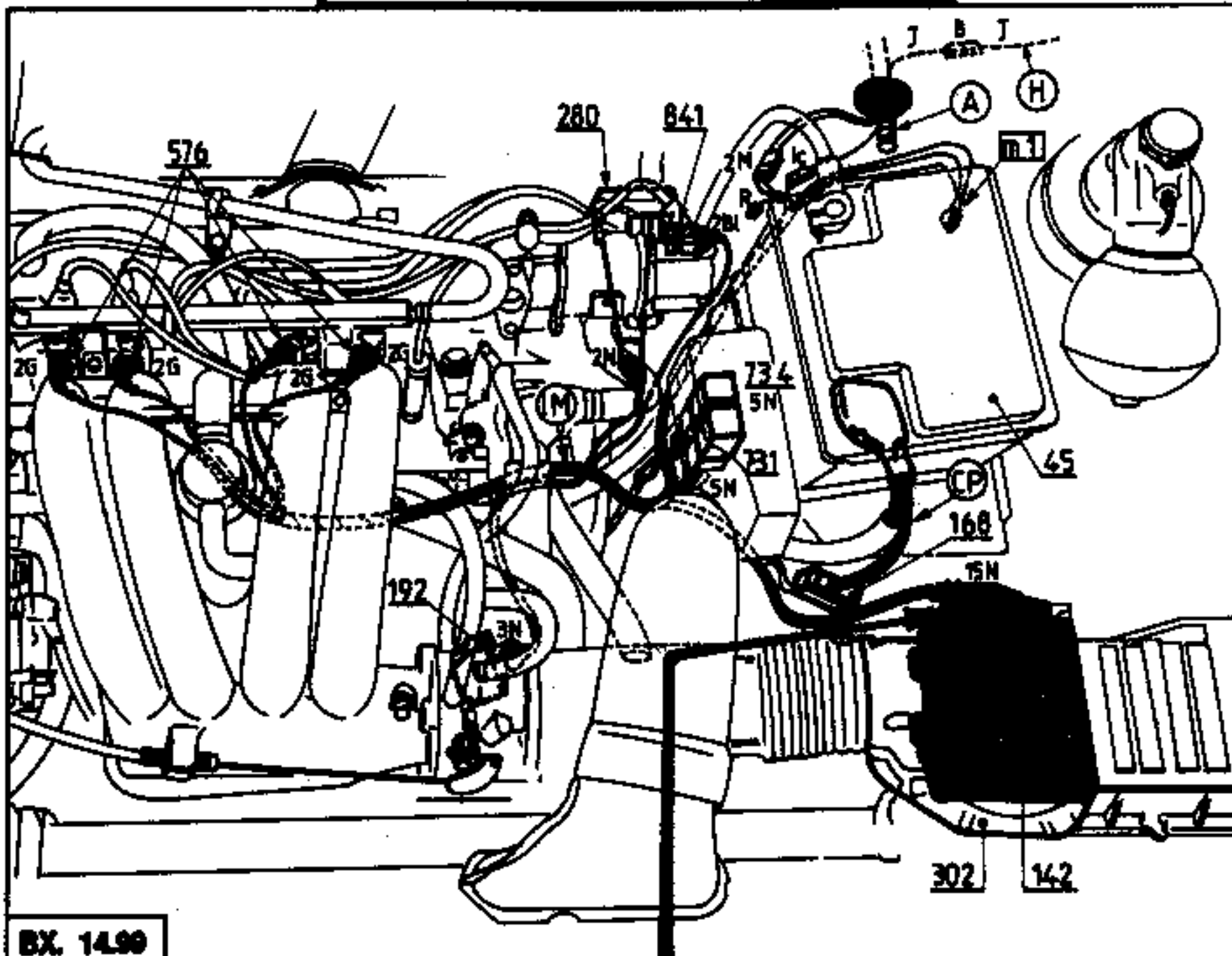

BX. 14.90

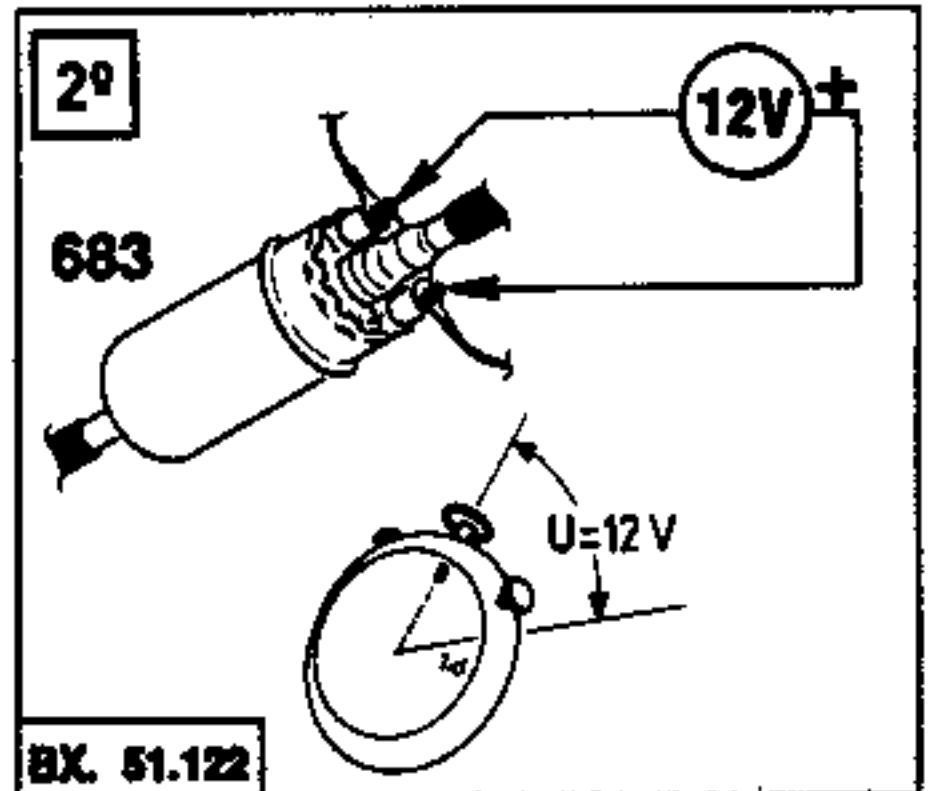
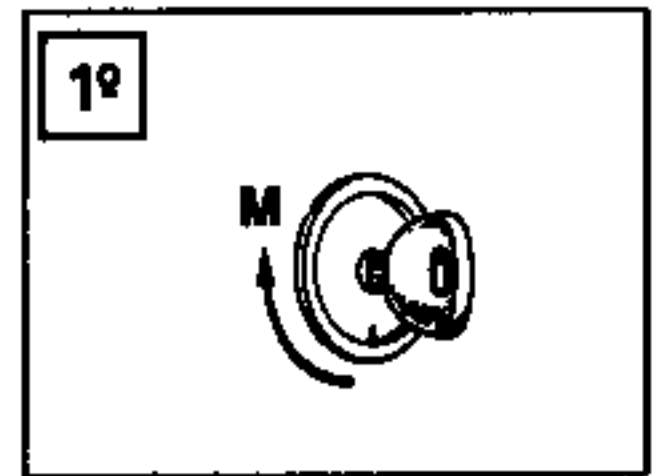

BX. 51.122

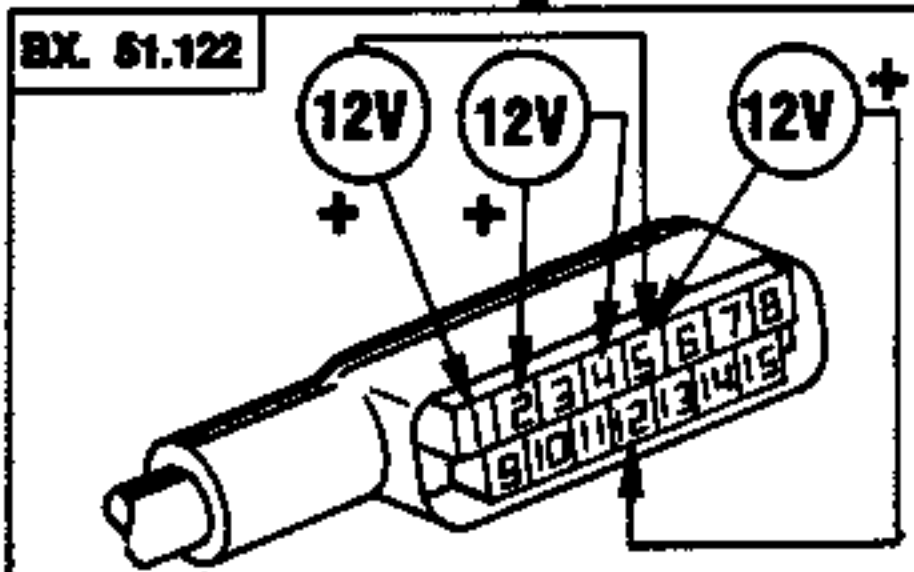

BX. 51.122

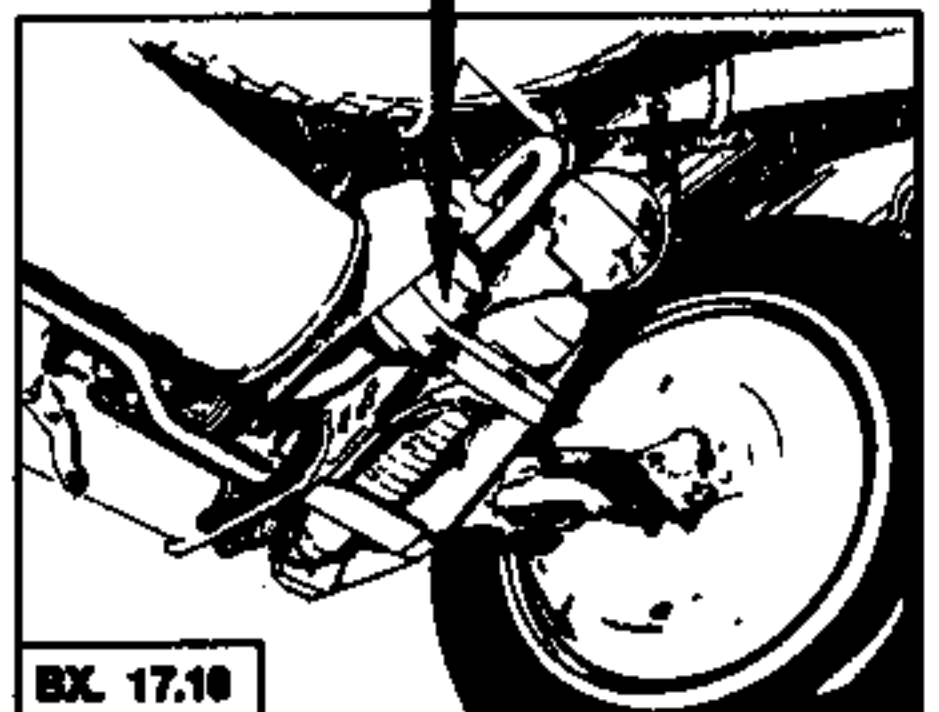

BX. 17.10

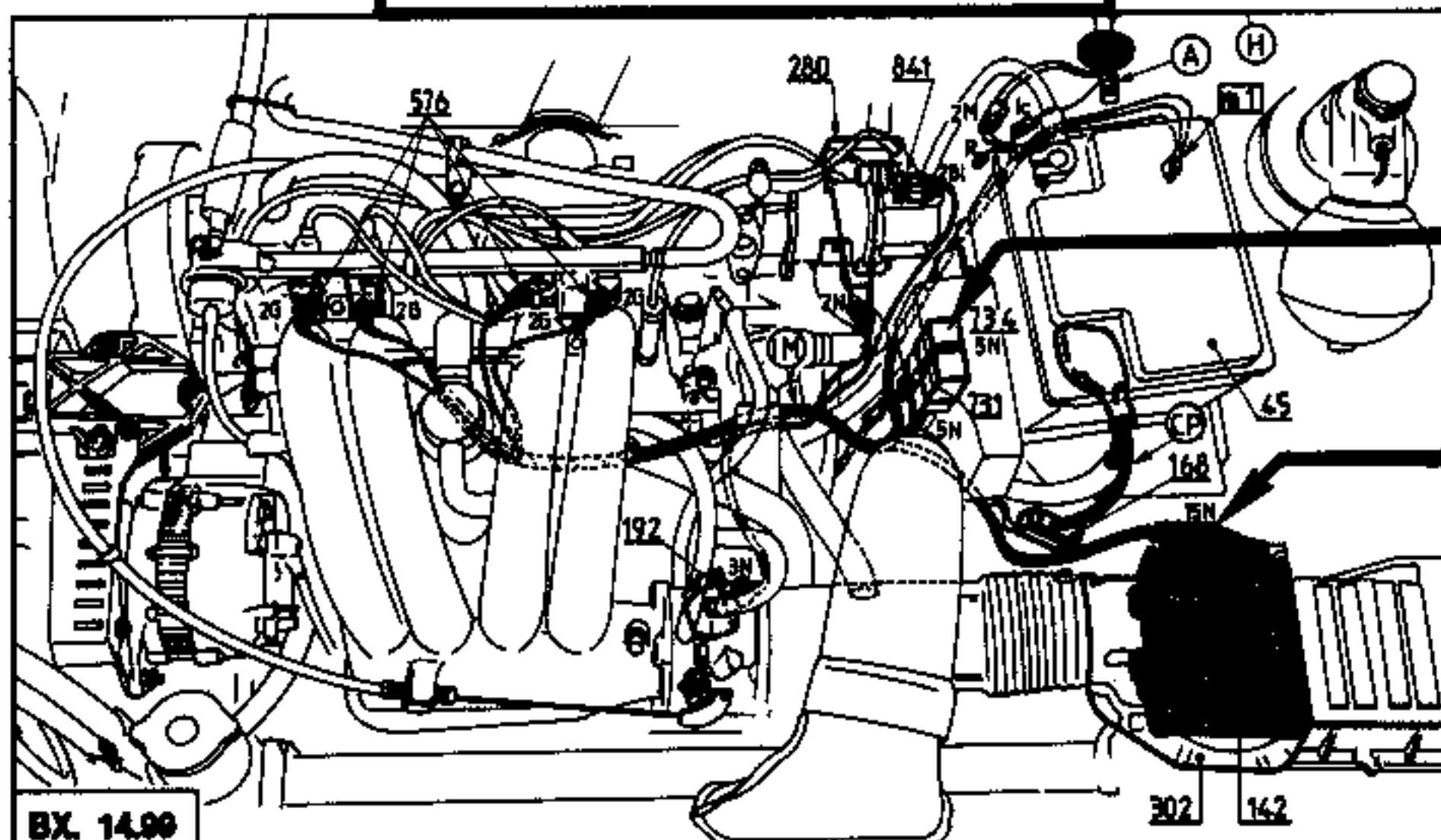

BX. 14.99

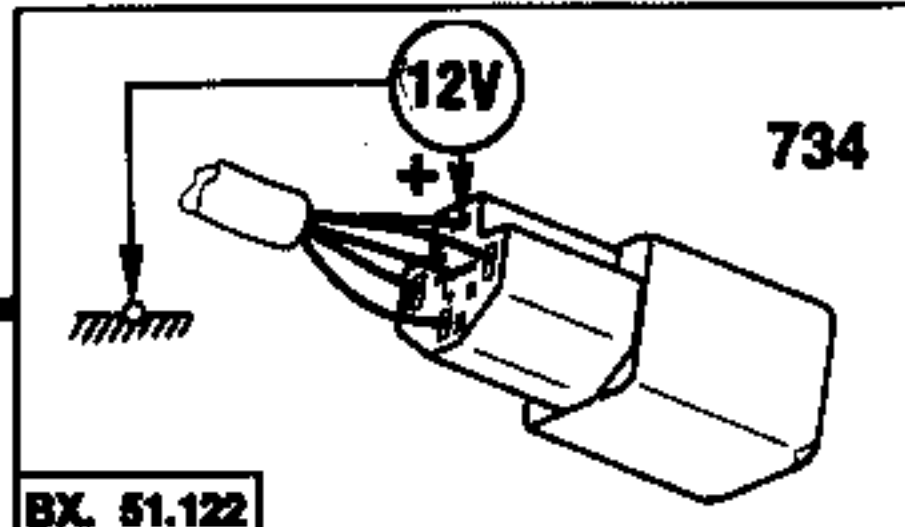

BX. 51.122

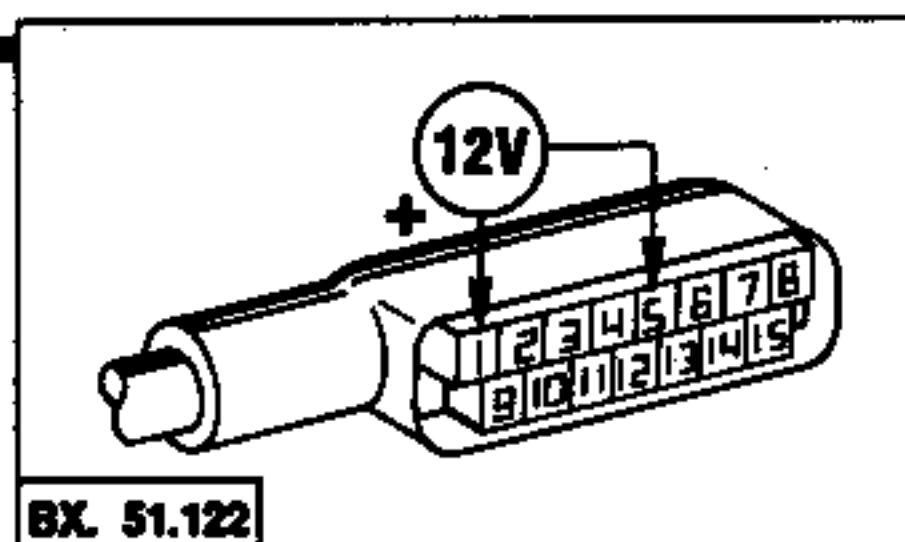

BX. 51.122



192

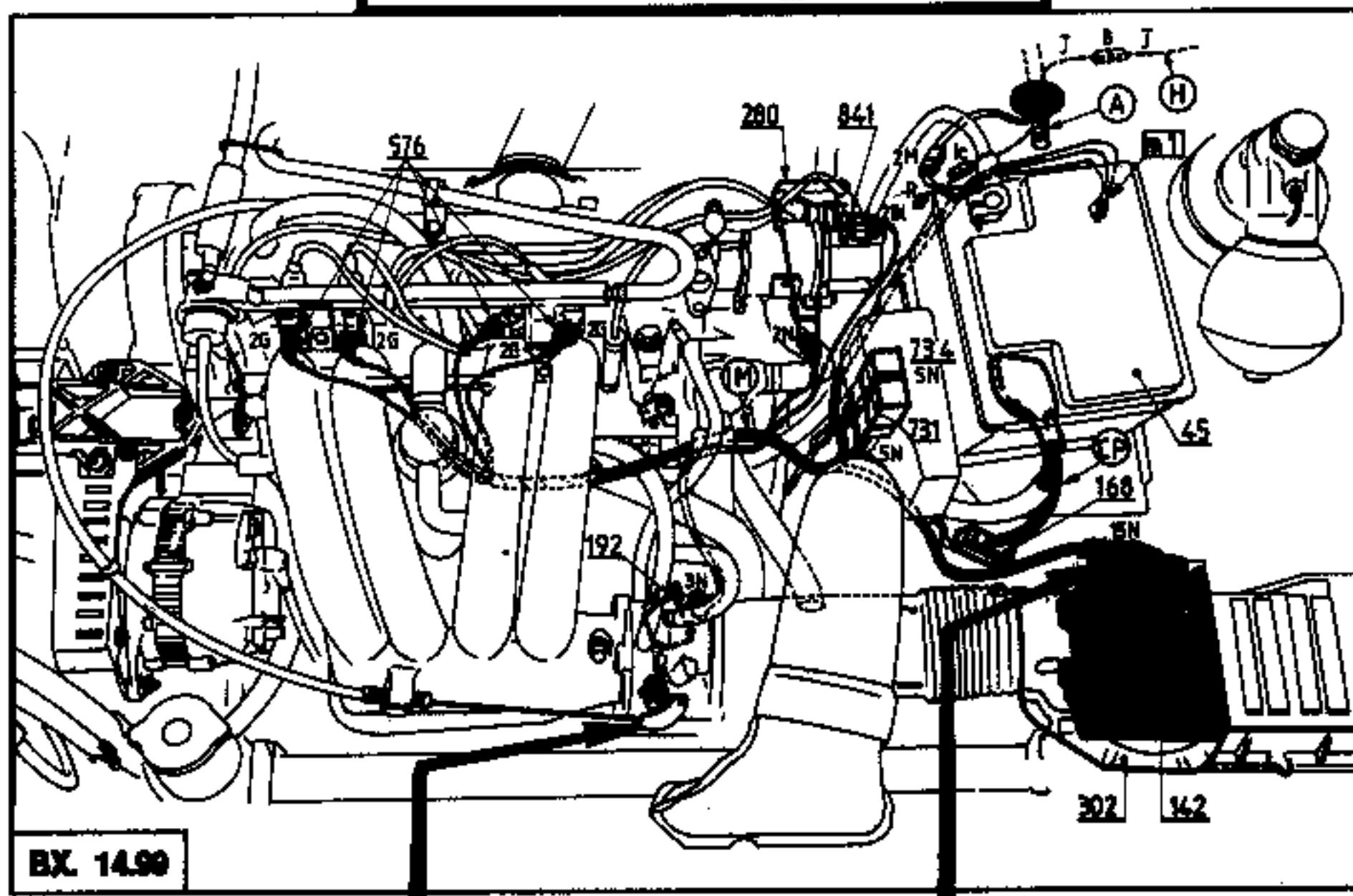

BX. 14.99

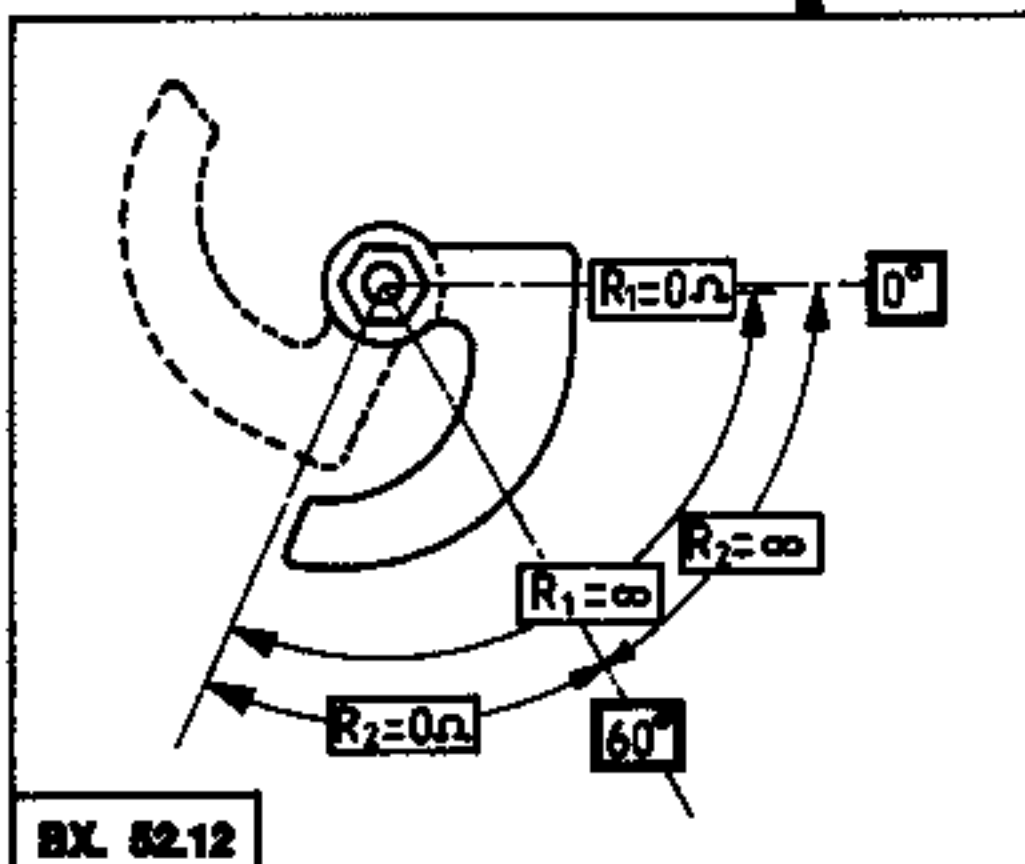

BX. 52.12

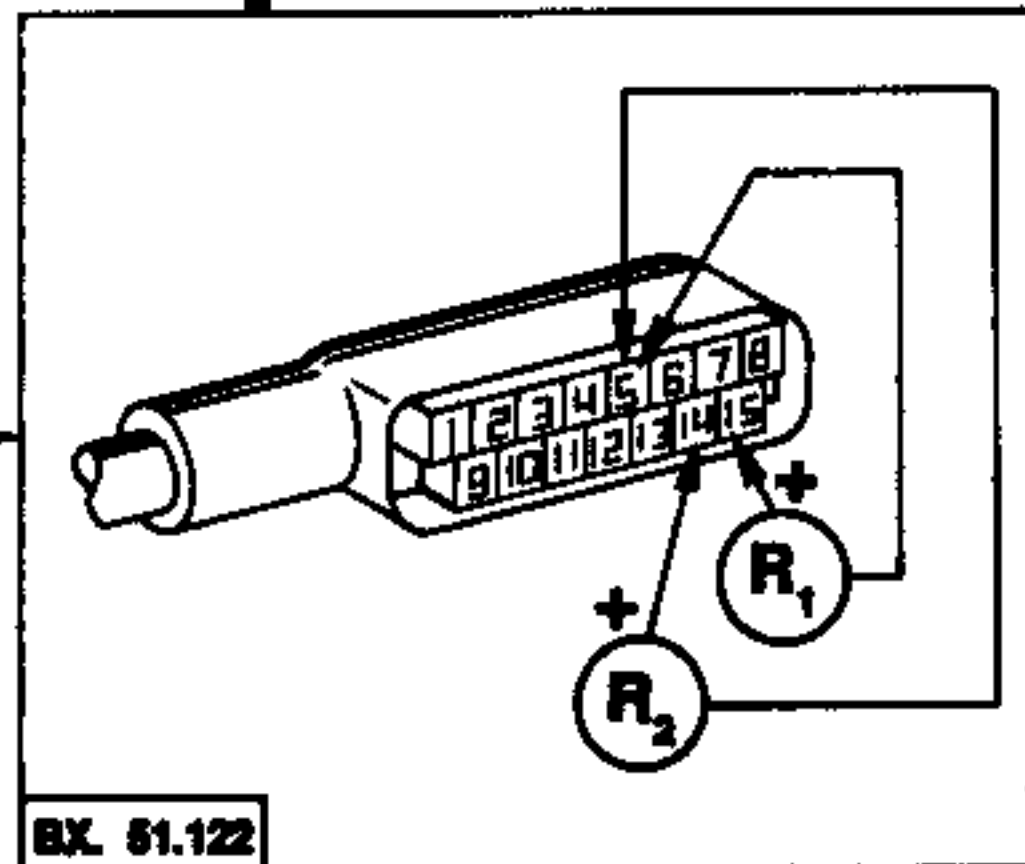

BX. 51.122

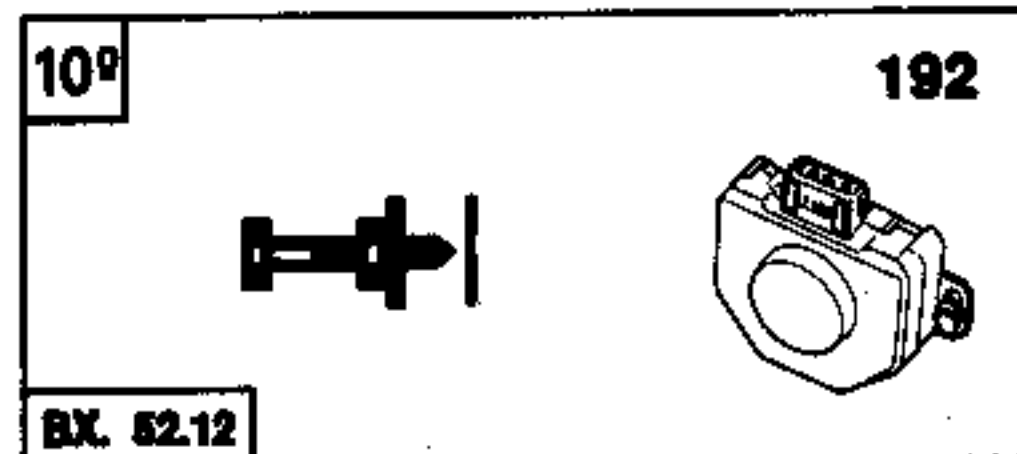
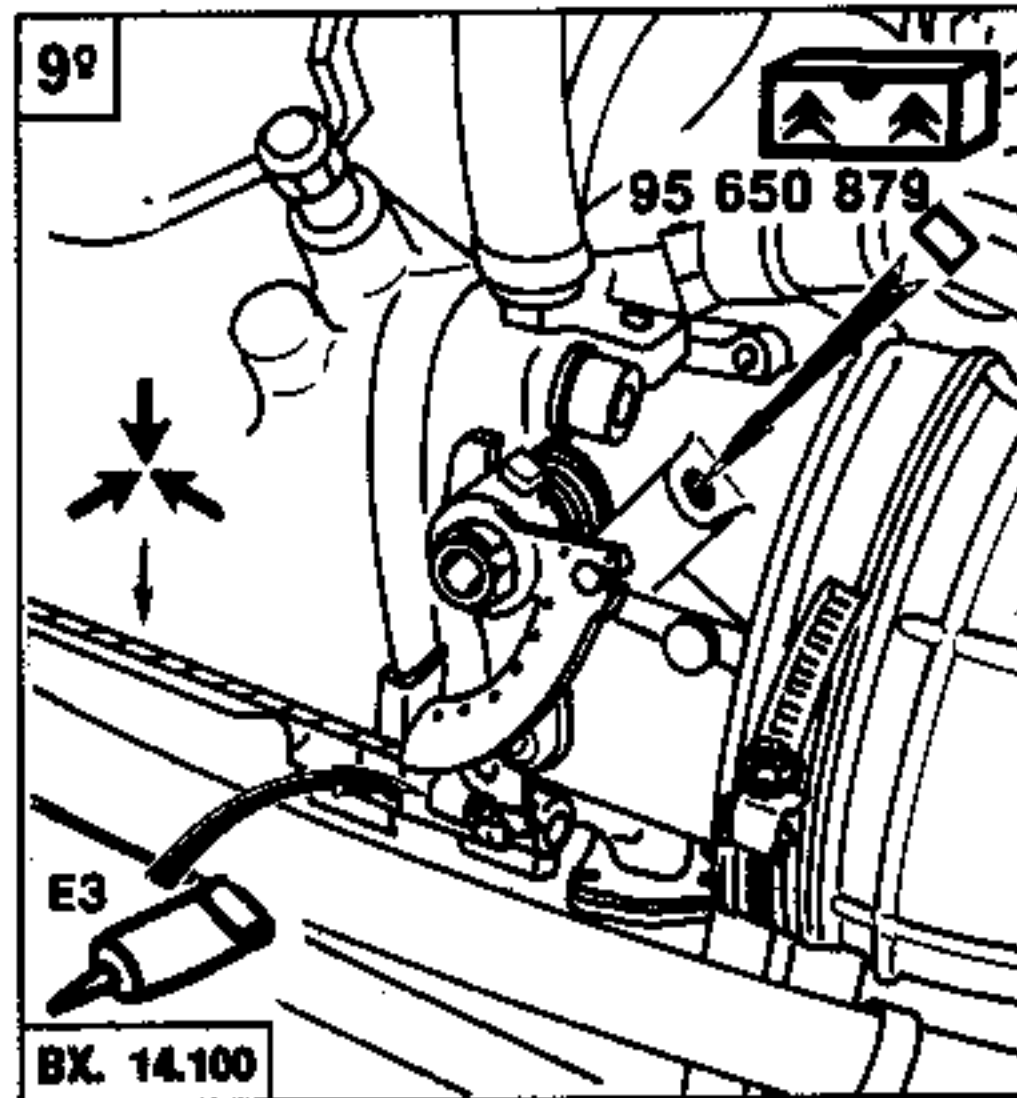
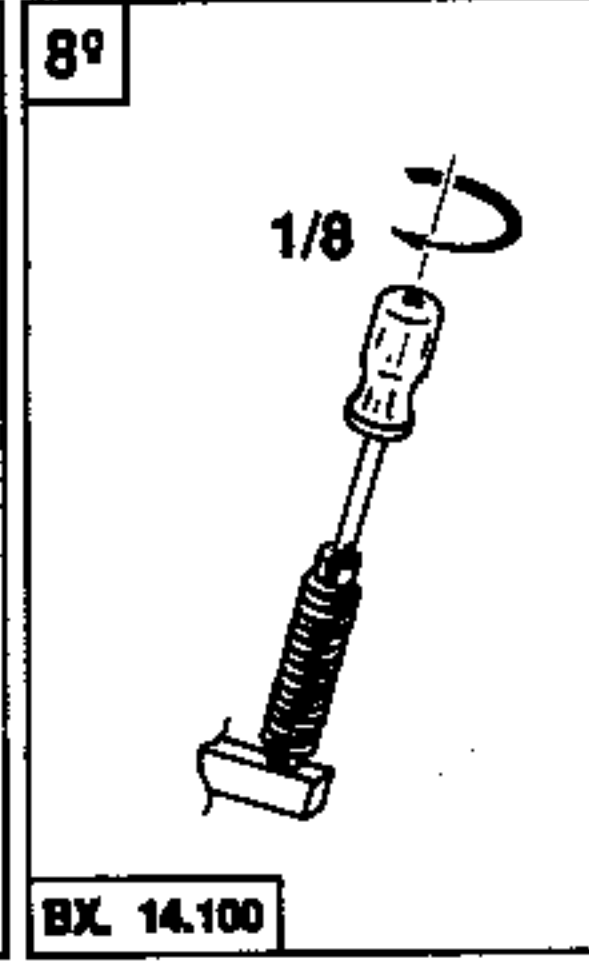
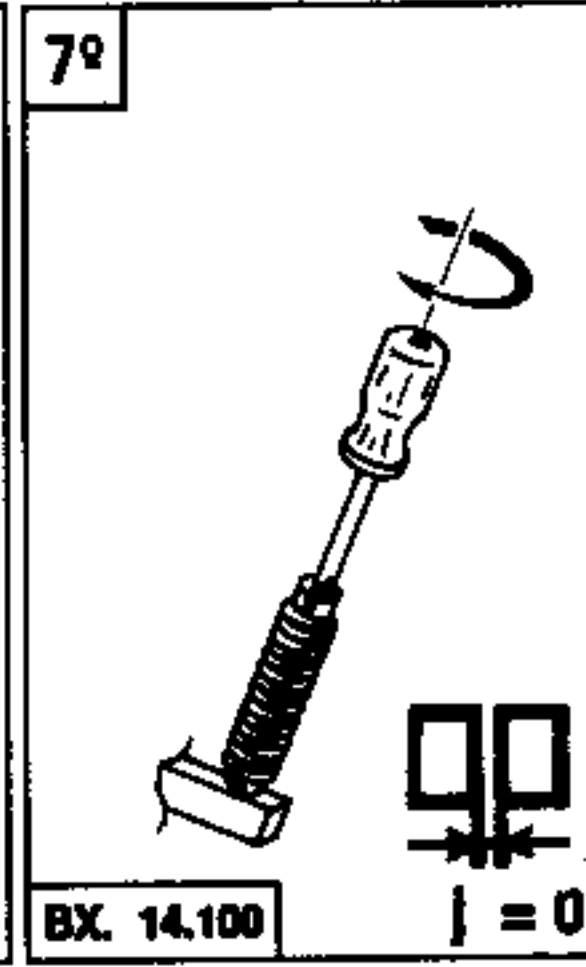
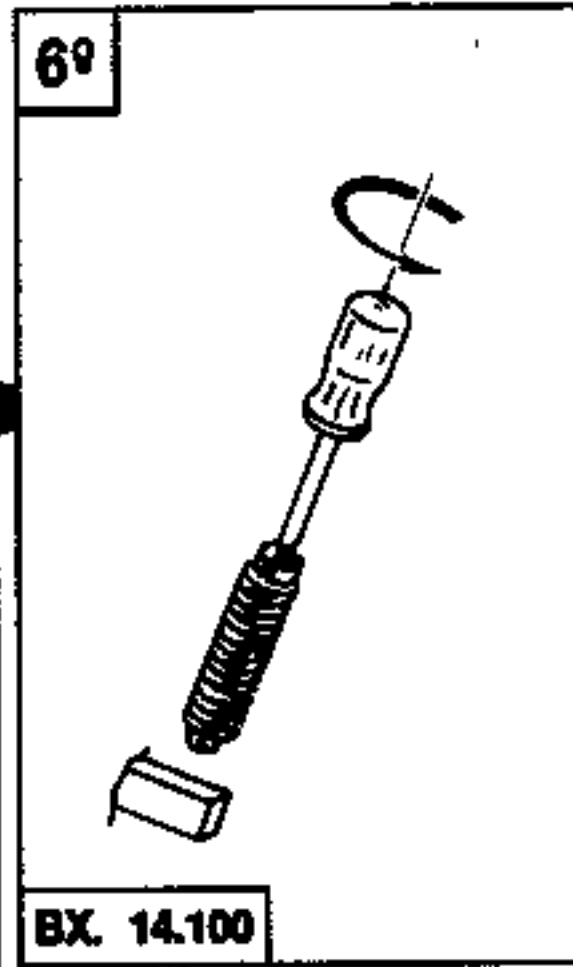
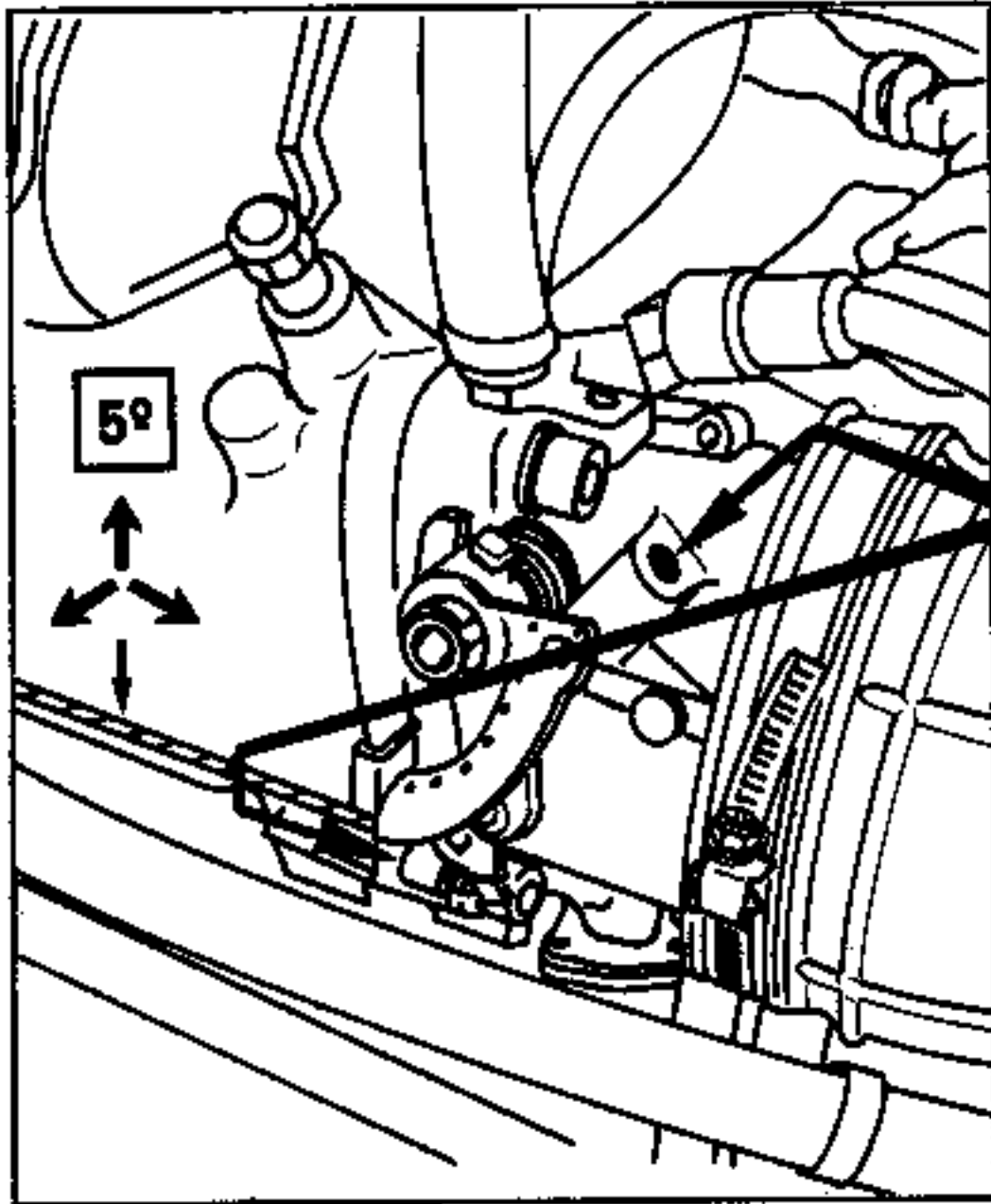
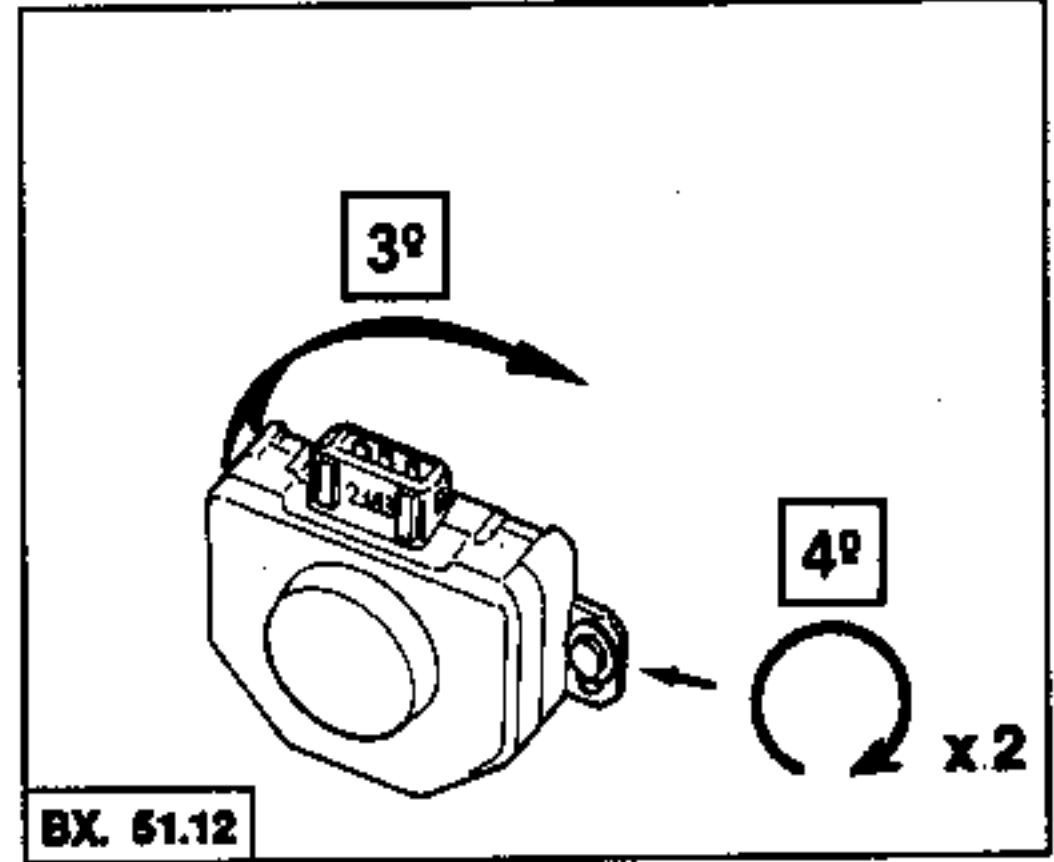
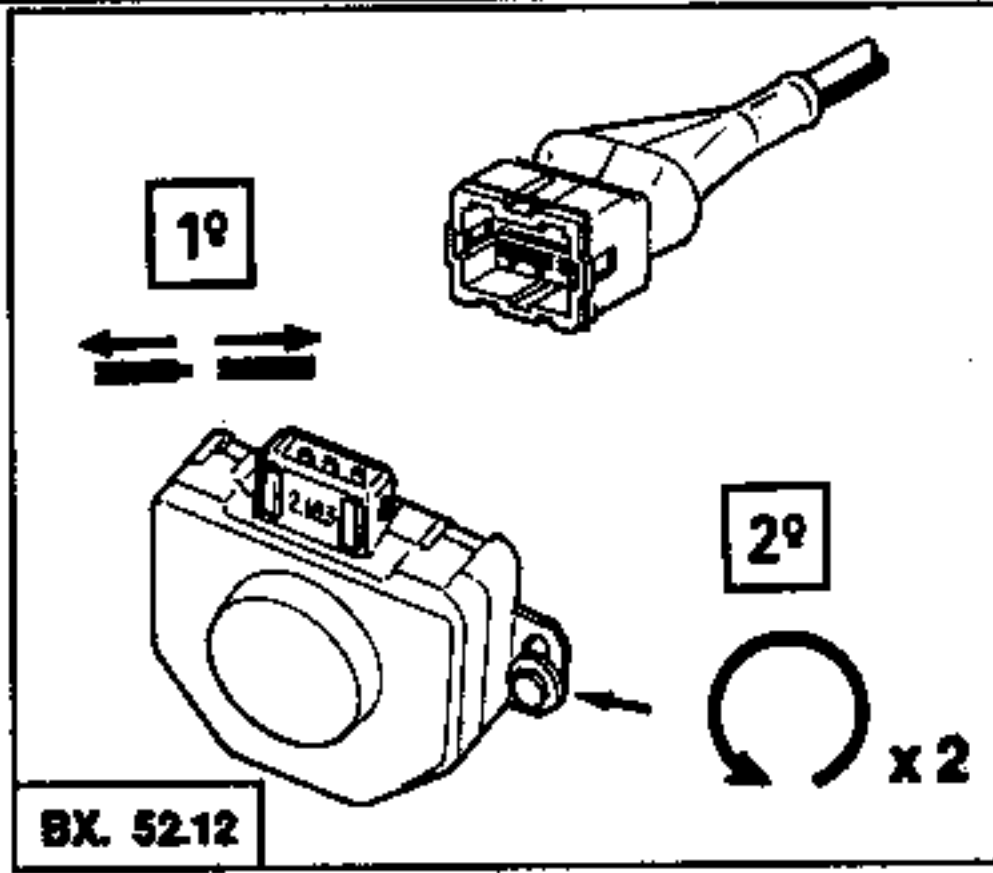
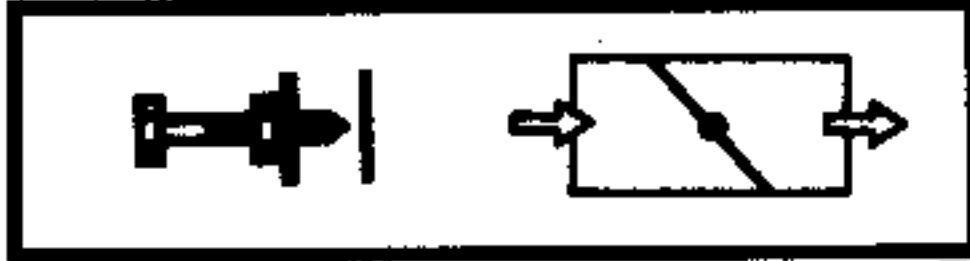

8

XB 19 E
144-00

BX 19 GTI

2

CITROËN

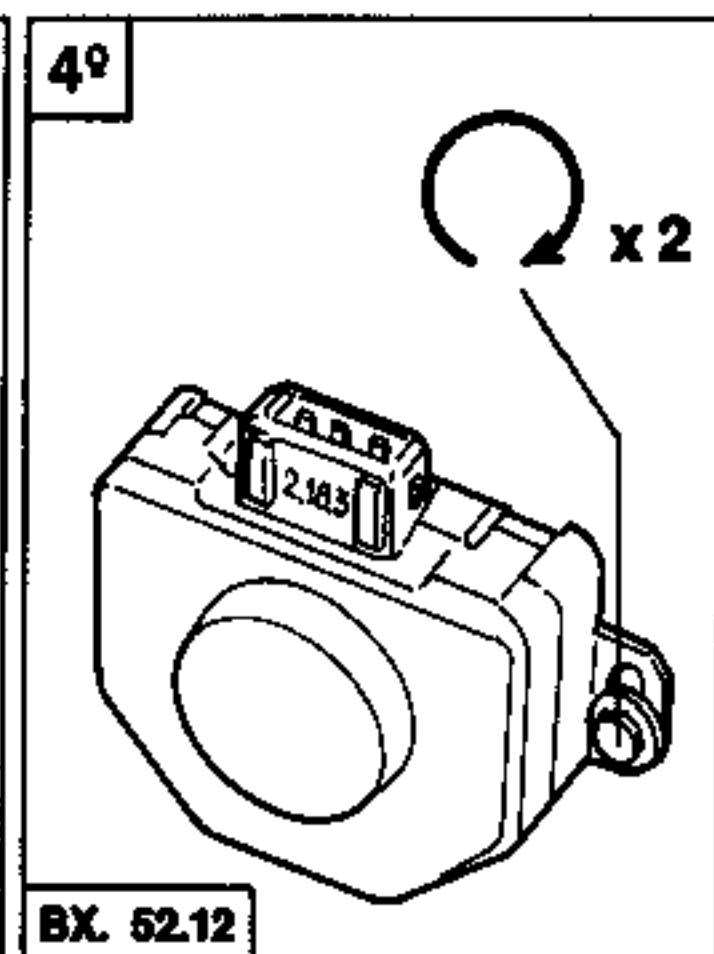
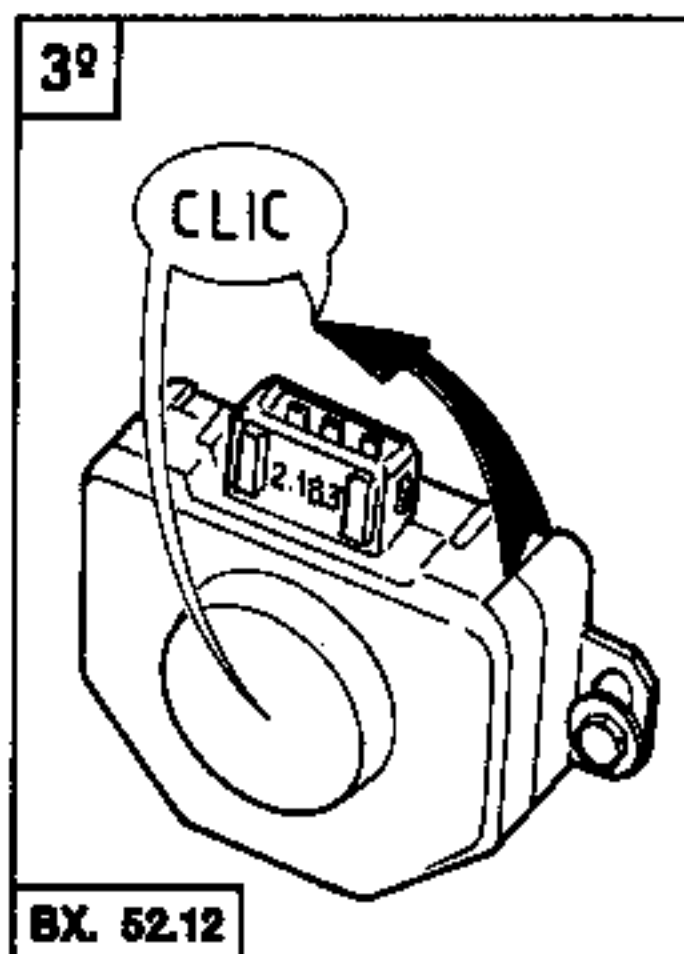
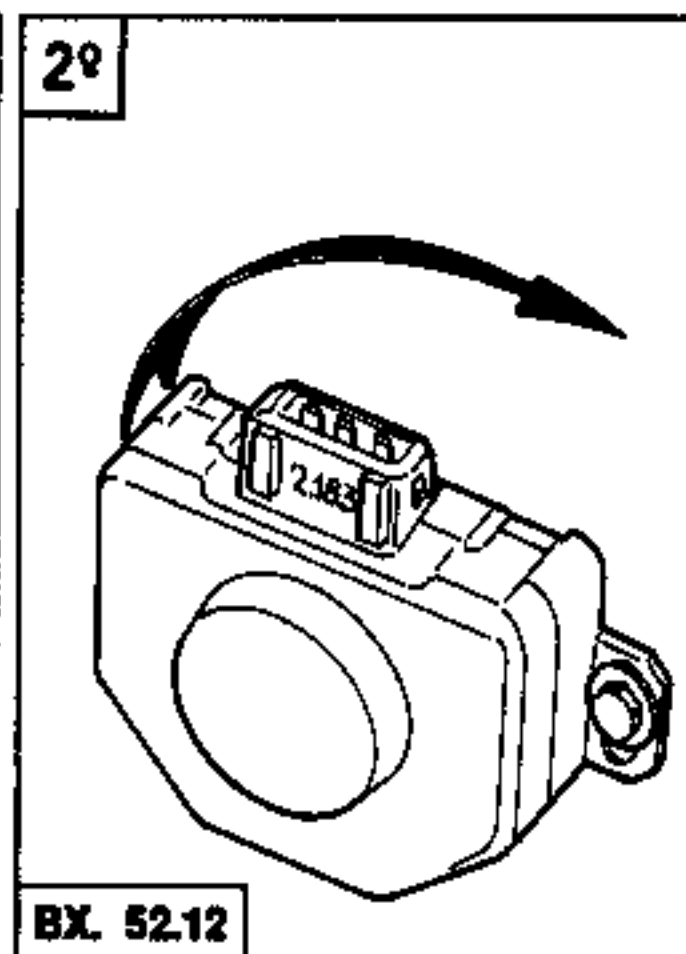
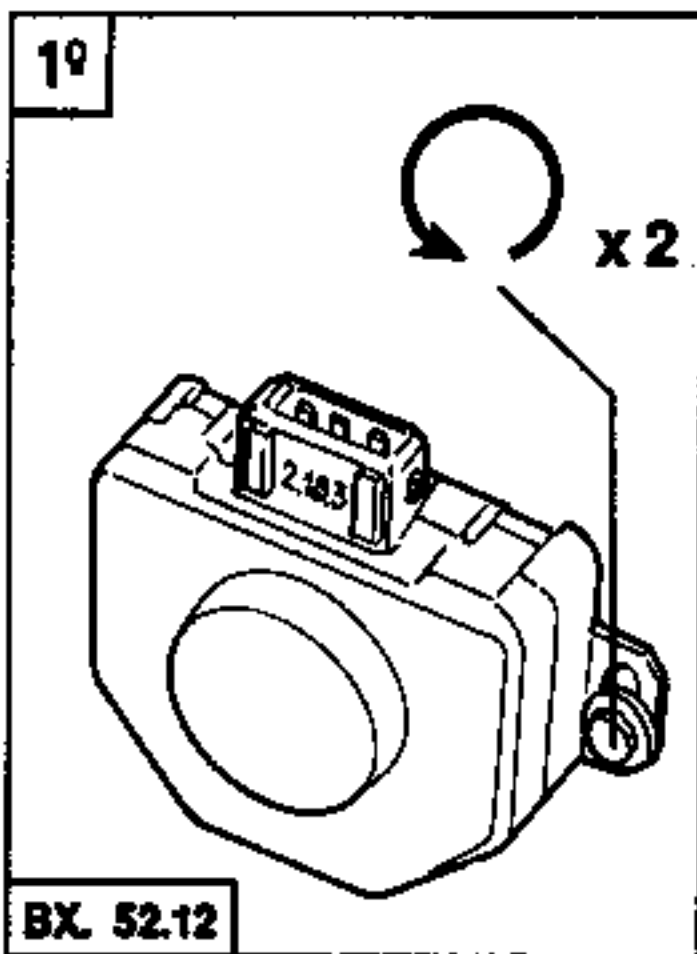
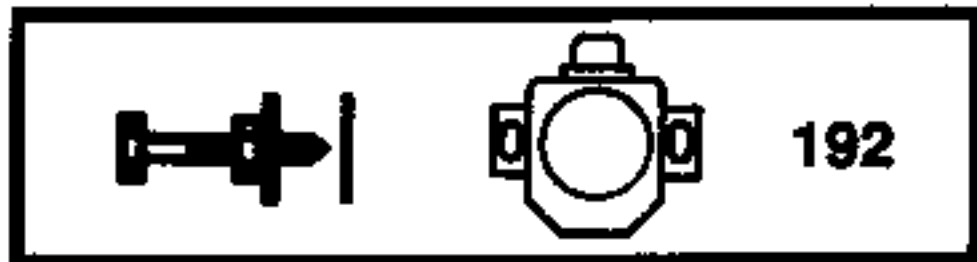

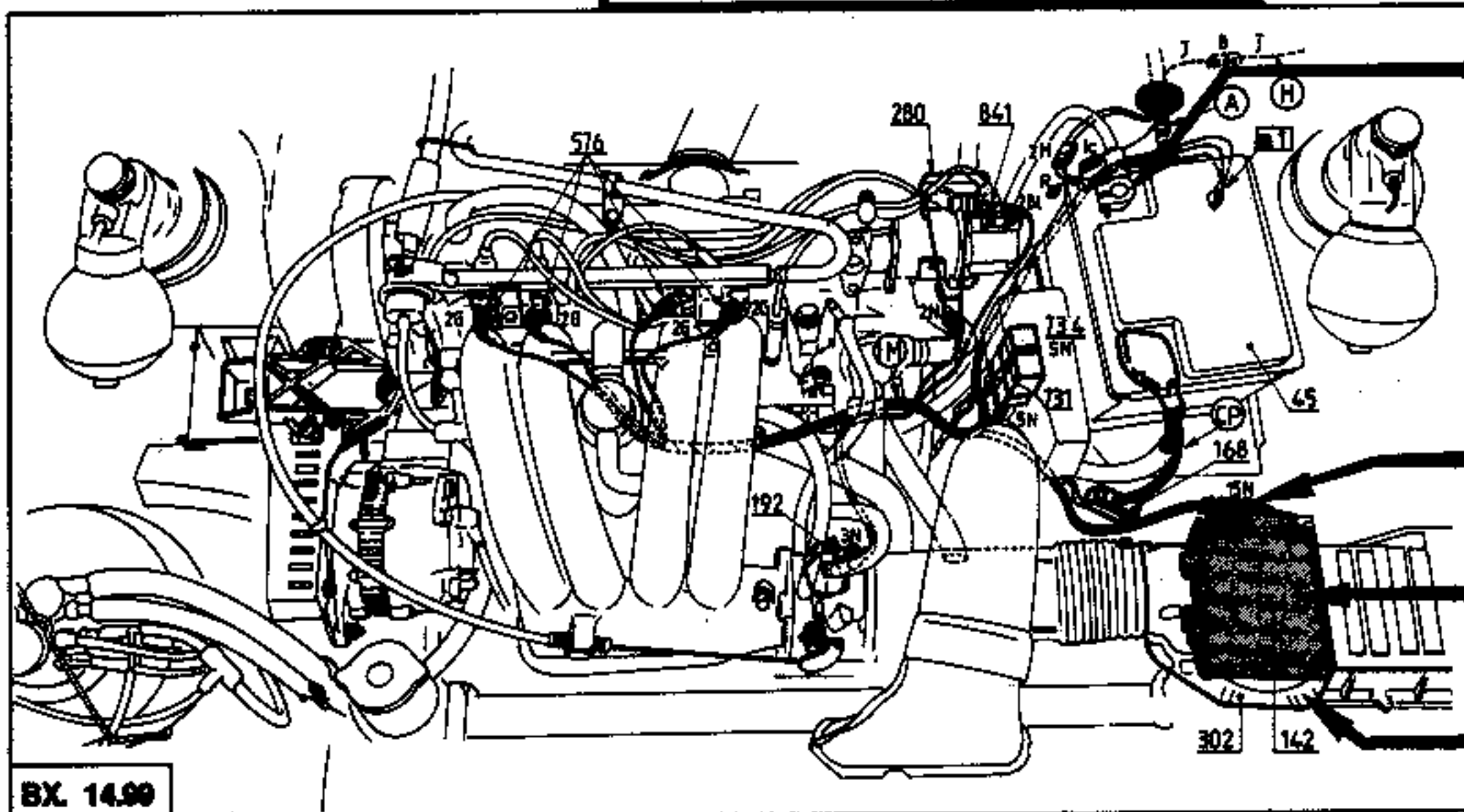

BX. 14.99

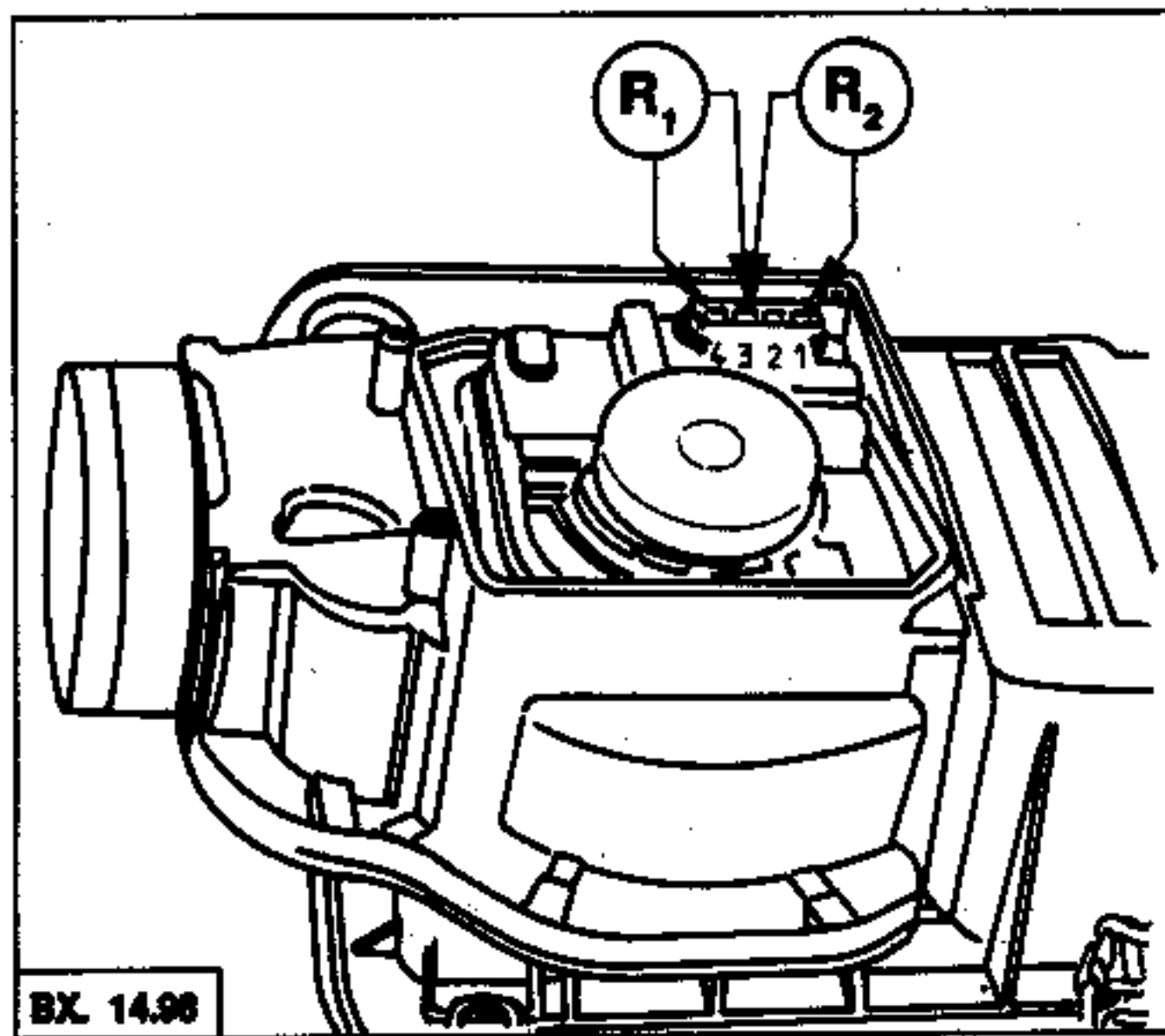
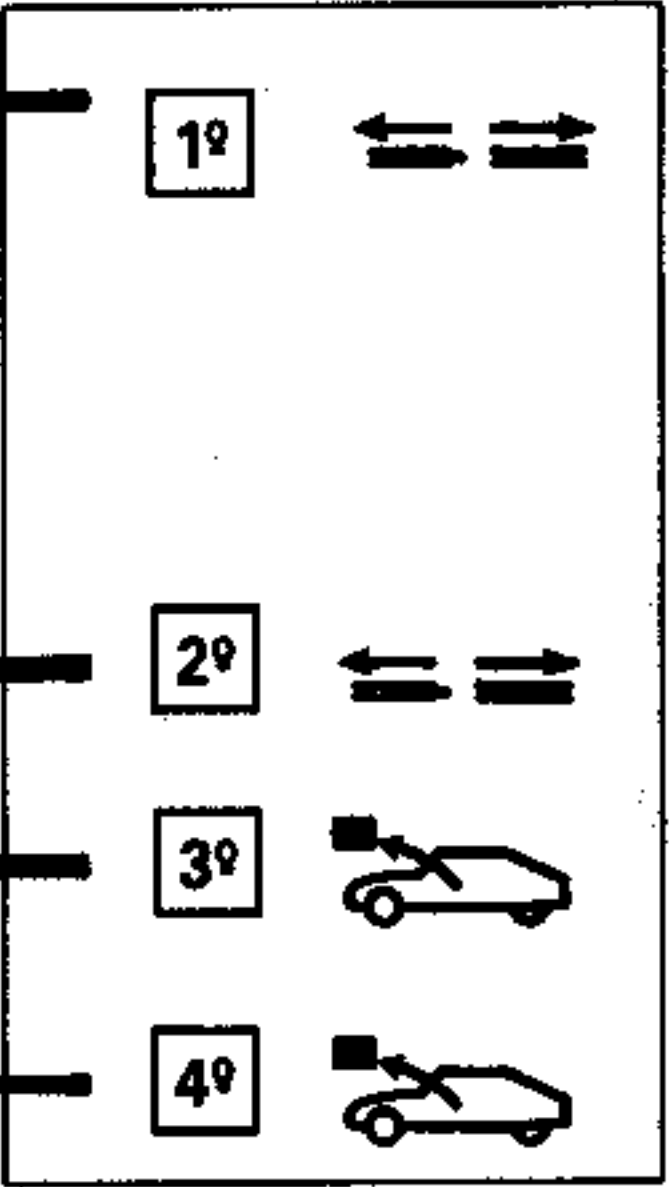

BX. 14.98

1°

$500 \Omega < R1 < 1000 \Omega$

2°

- = -10° C $8260 \Omega < R2 < 10560 \Omega$
- = +20° C $2280 \Omega < R2 < 2720 \Omega$
- = +50° C $760 \Omega < R2 < 910 \Omega$

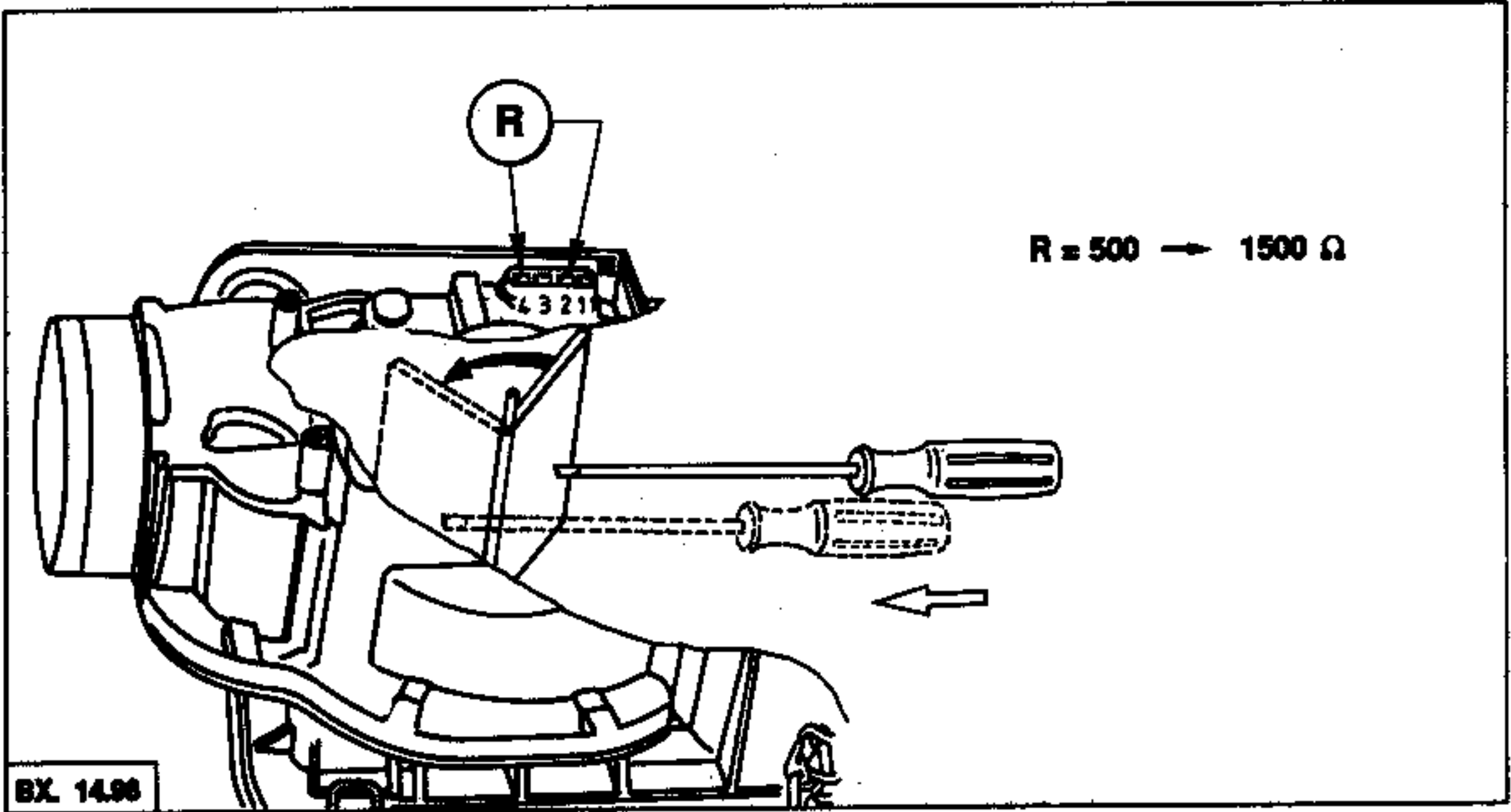

BX. 14.98

$R = 500 \rightarrow 1500 \Omega$



280

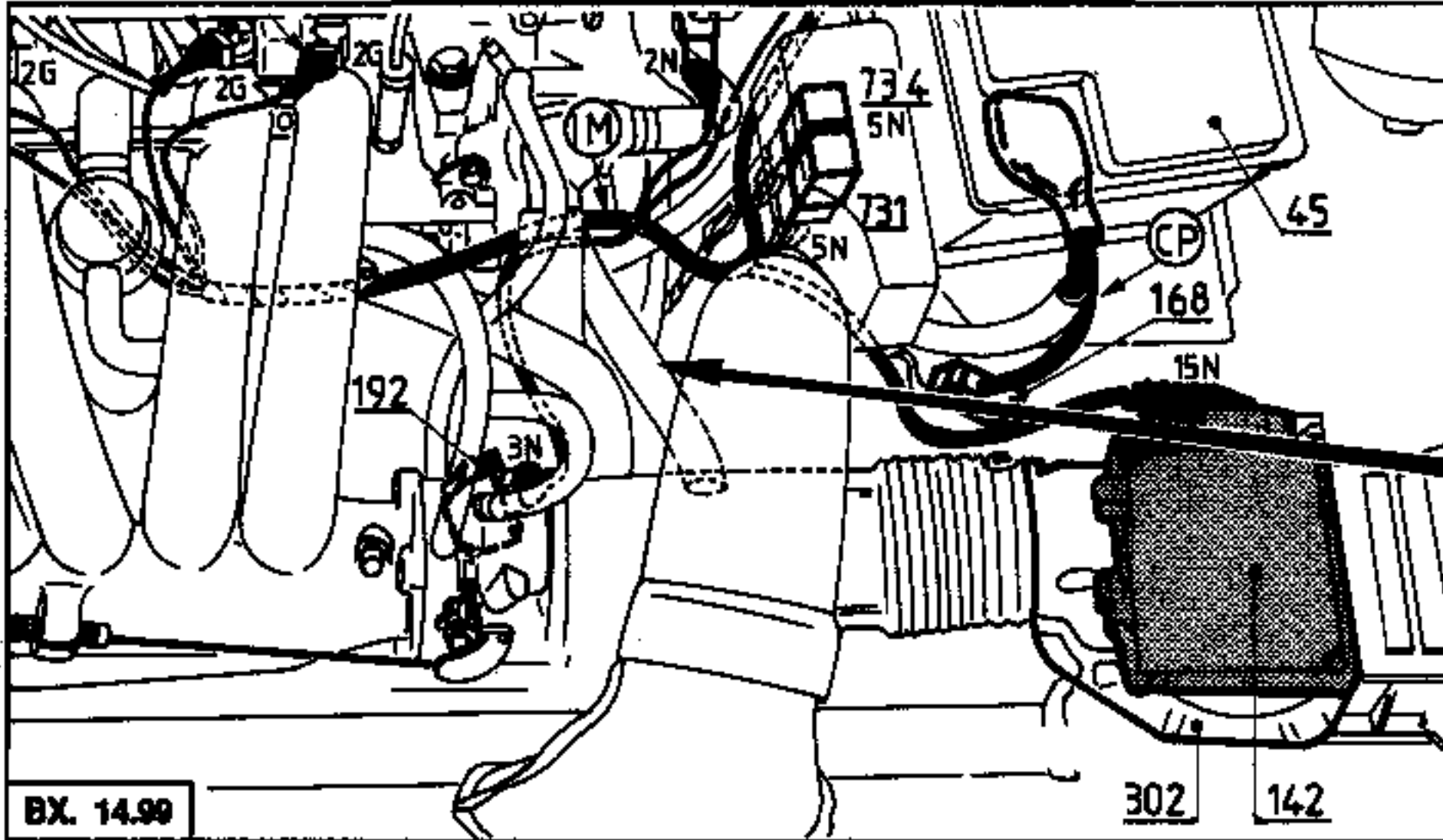

BX. 14.99

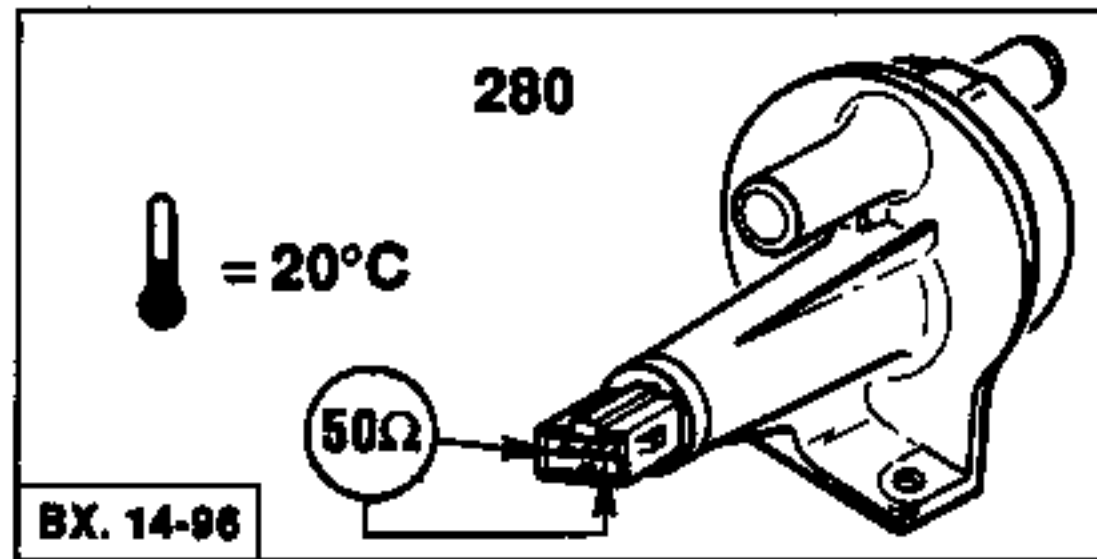
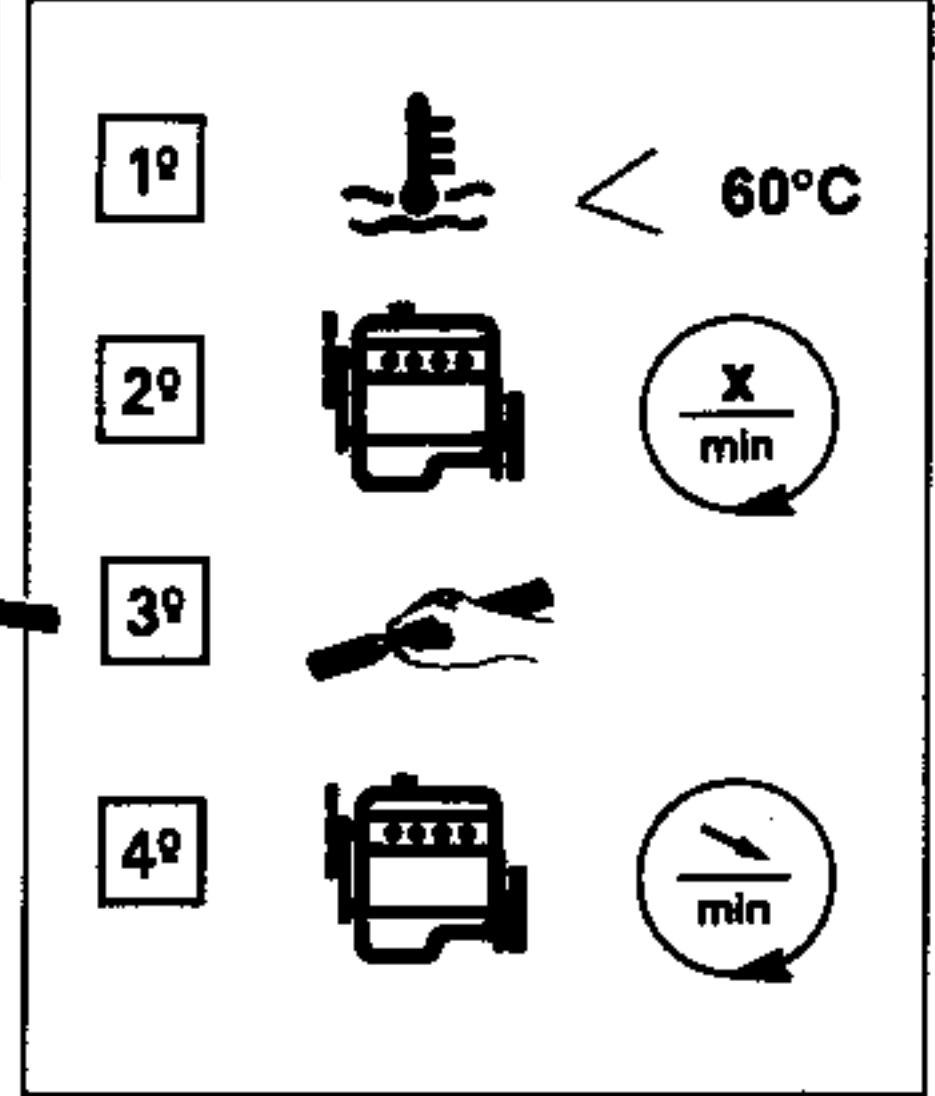

BX. 14.96



576

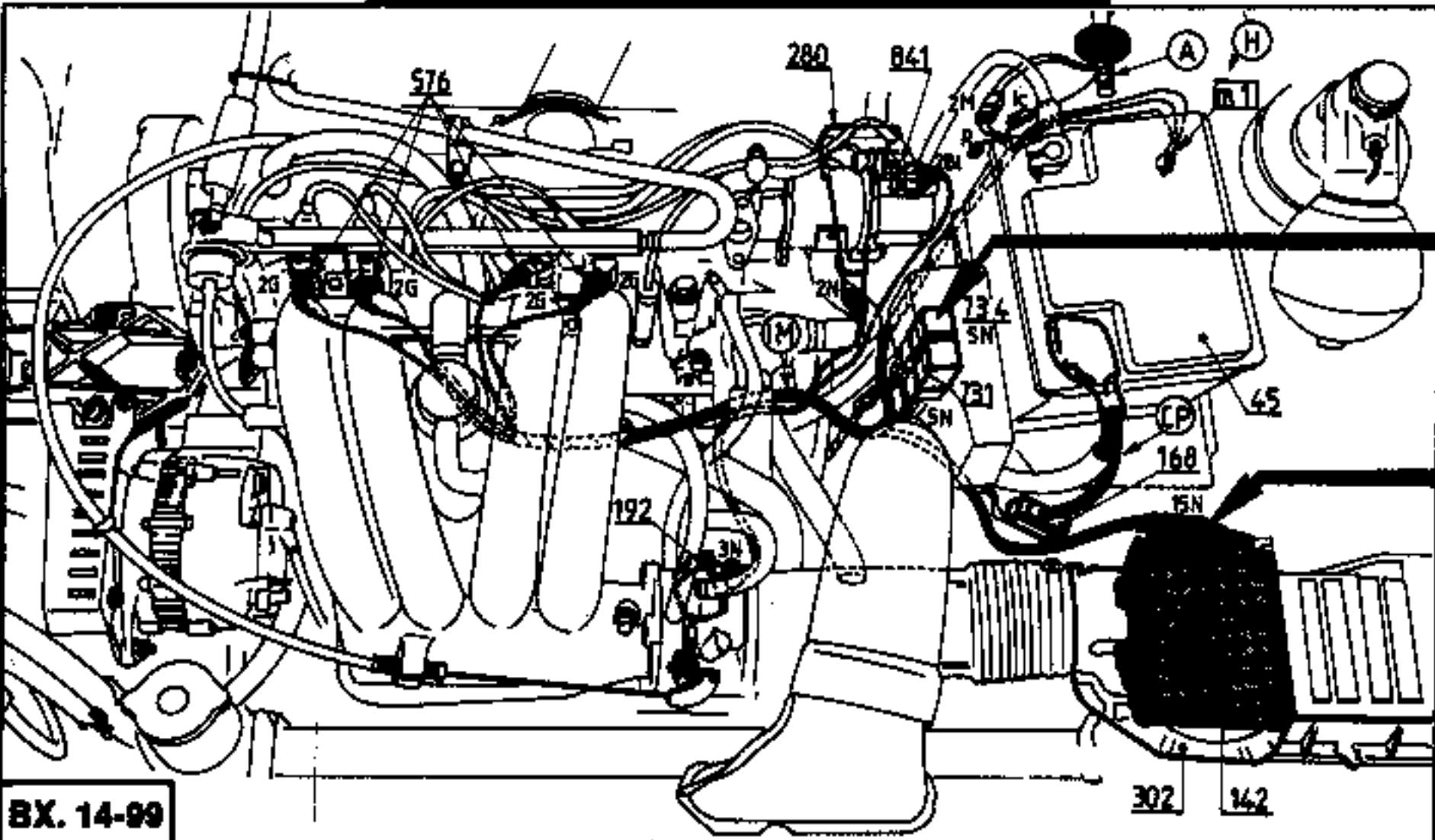

BX. 14.99

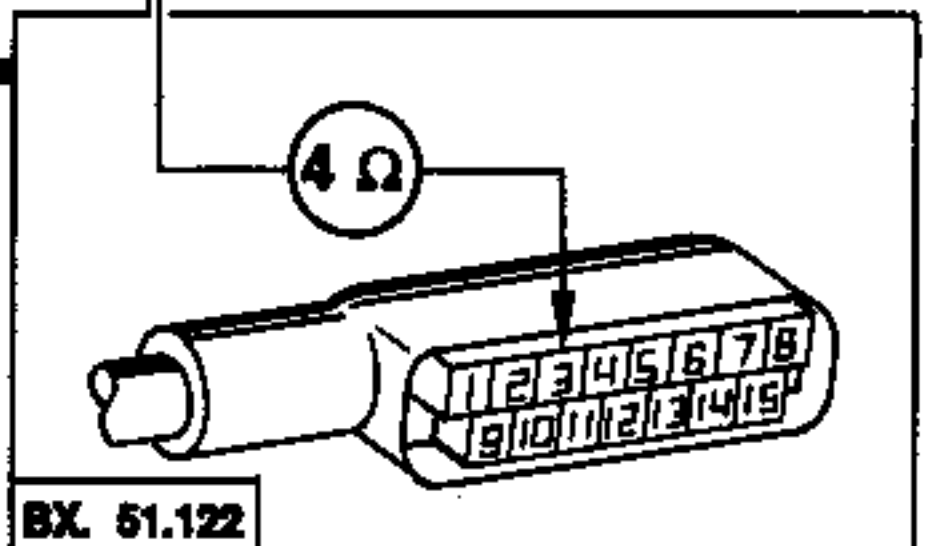
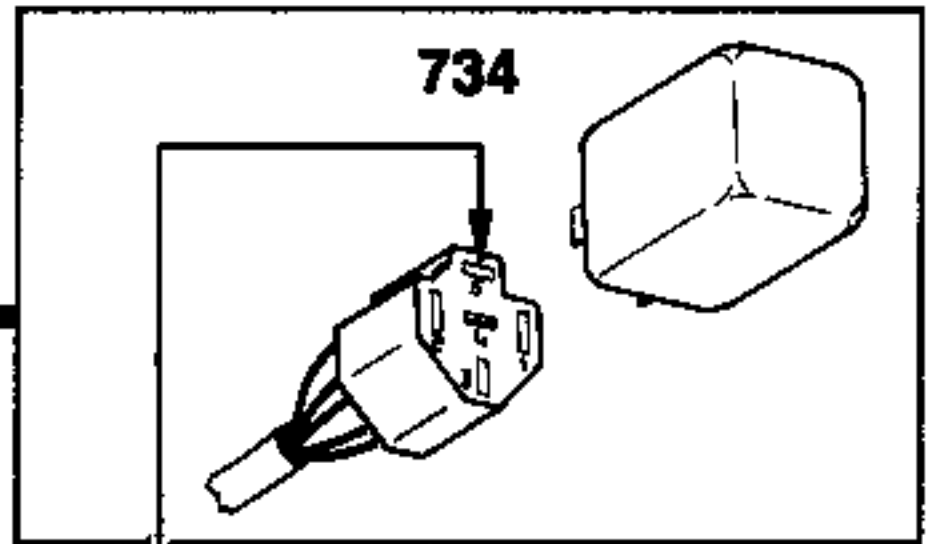

BX. 51.122

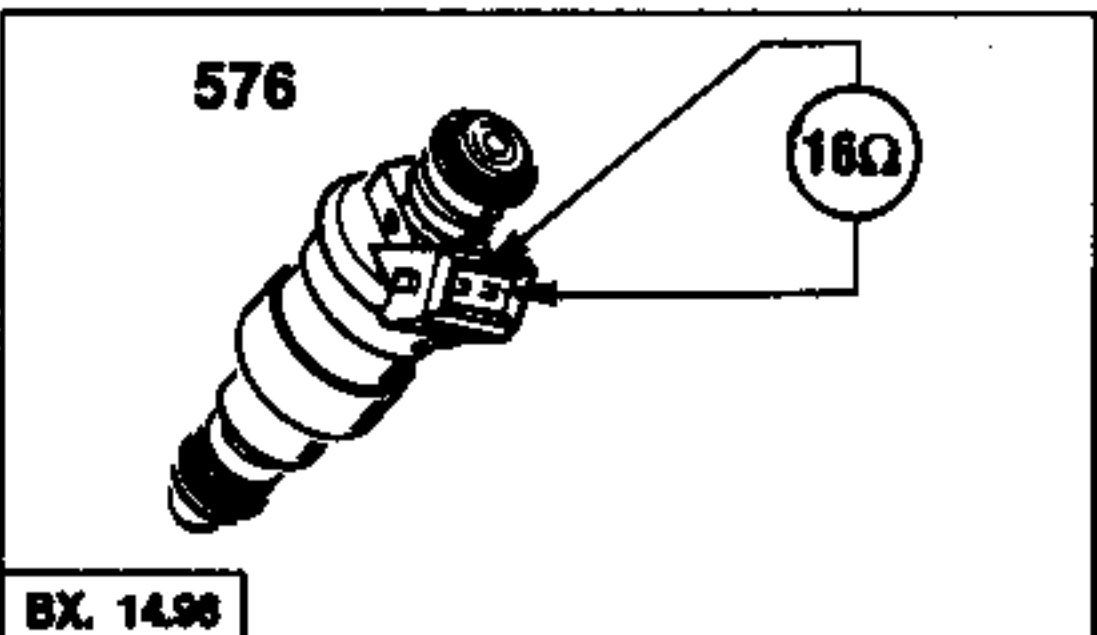

BX. 14.96



841

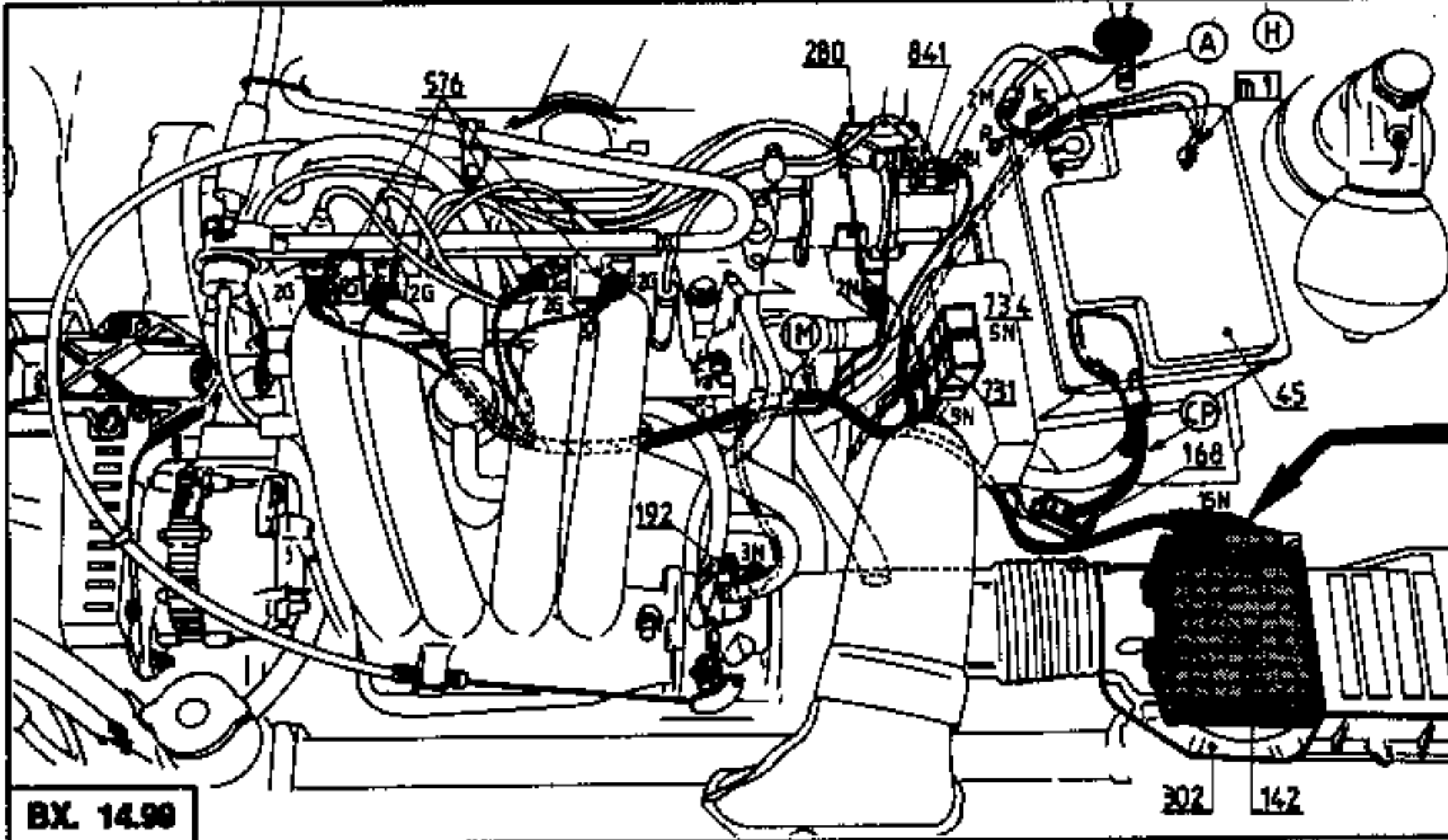

BX. 14.99

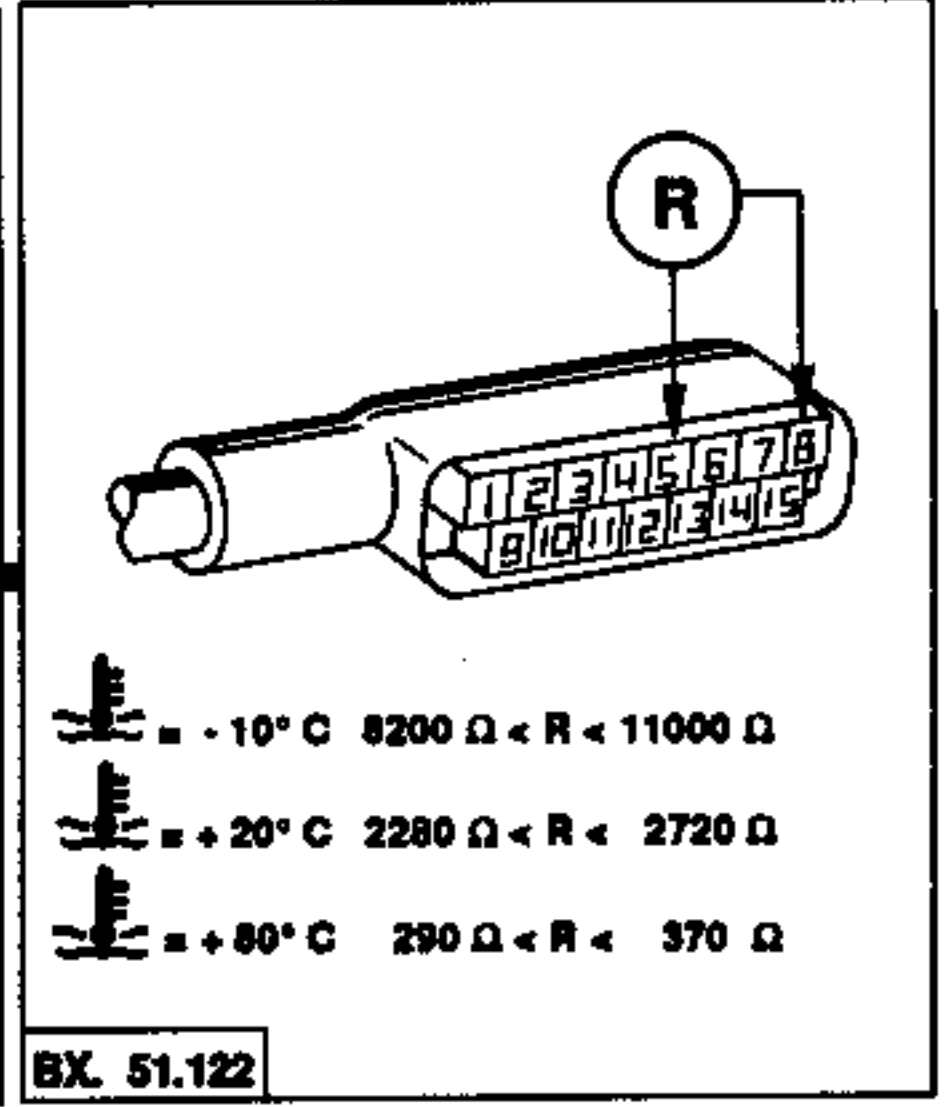

BX. 51.122

CO, CO₂

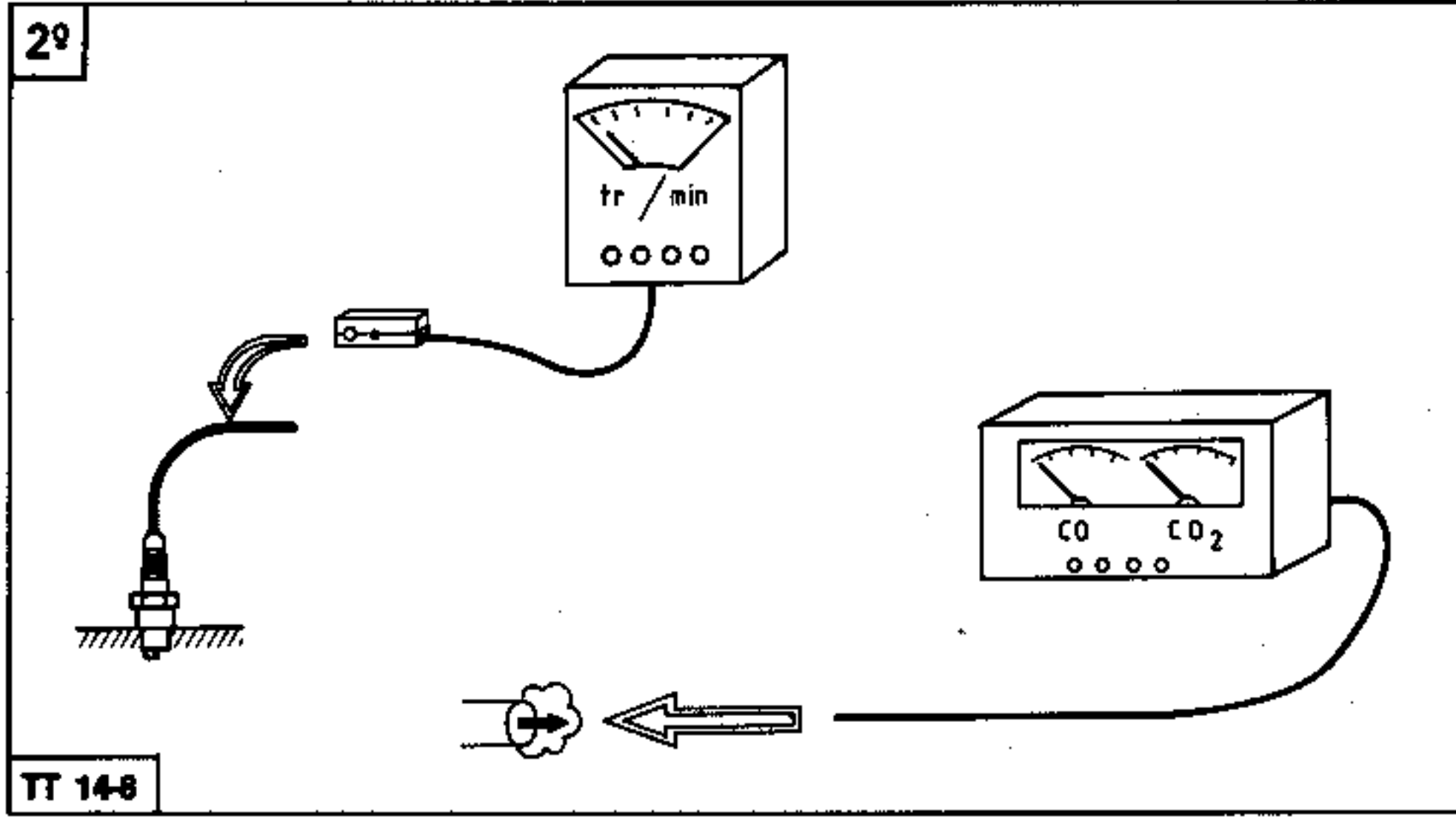
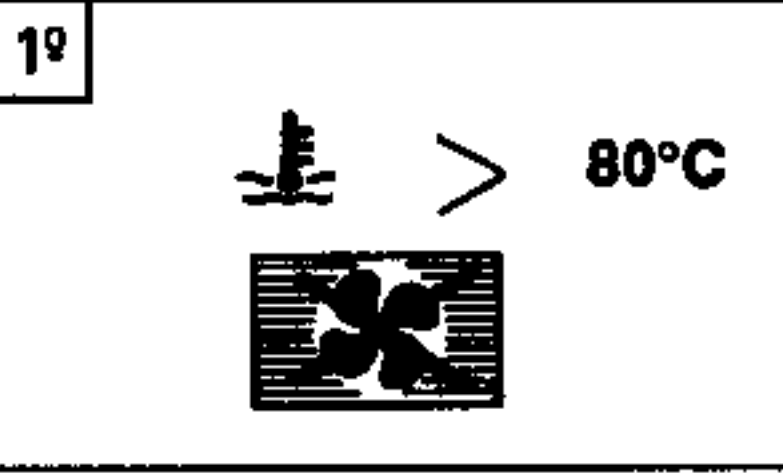

3°

tr/min	CO	CO ₂
800 ⁺⁵⁰ 0 tr/min	2%	>10%

